

Dharmacon™ SMARTvector™ Inducible Lentiviral shRNA Lentiviral Particles Safety Information

Introduction:

Safety is a focus of all lentiviral vector technology. For this reason, lentiviral vector packaging systems have divided the essential functions amongst multiple plasmids to reduce the risk of generating replication-competent lentivirus (RCL). The split-genome packaging system is designed so that multiple recombination events between the components are required for autonomous replication. Clinical trials using a split-genome packaging system have shown that this strategy effectively eliminates the creation of RCLs (see Levine *et. al.* PNAS, 103:17372-17377, 2006). Commercially available 3rd generation lentiviral vector systems separate the viral envelope, env (e.g. VSV-G) from the gag-pro-pol, which encodes structural and enzymatic functions. SMARTvector Inducible Lentiviral shRNA Particles are produced using the Trans-Lentiviral Packaging System. The Trans-Lentiviral Packaging system provides an even higher level of safety over 3rd generation packaging systems by further splitting the viral pol (reverse transcriptase (RT) and integrase (IN) functions) from gag-pro. Because the RT and IN enzymes are provided in trans to gag-pro, additional recombination events are necessary to produce RCLs.

SMARTvector Inducible Lentiviral shRNA Lentiviral Vector Technology:

The SMARTvector Inducible Lentiviral shRNA transfer vector consists of a deleted HIV-1 pNL4-3 provirus that retains only those cis-acting sequences necessary for packaging, reverse transcription and integration (Figure 1). SMARTvector Inducible shRNA lentiviral particles are replication incompetent, containing less than 30% of the wild-type HIV-1 genome. Furthermore, all essential replication *genes*, *gag*, *pol*, and *env*, and accessory *genes*, *tat*, *rev*, *vif*, *vpr*, *vpu*, and *nef*, have been removed.

The viral sequences contained in the SMARTvector Inducible shRNA lentivector genome include:

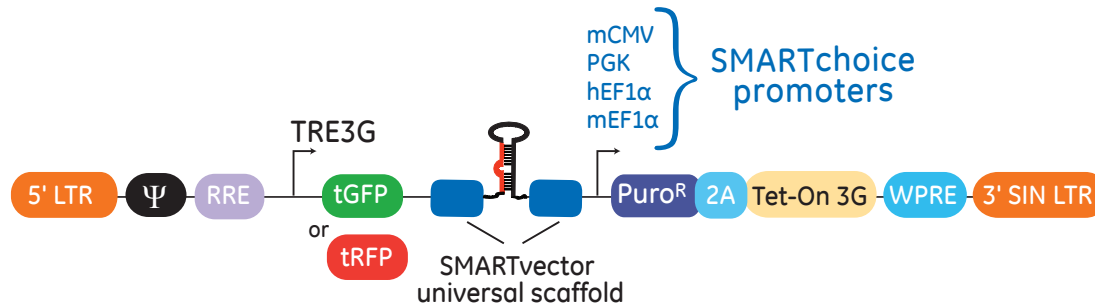

Figure 1. SMARTvector Inducible shRNA genome

1. A 5' long terminal repeat (LTR);
2. A primer binding site (PBS) complementary to tRNA^{Lys3} for initiation of reverse transcription and minus strand DNA synthesis;
3. A sequence encompassing the HIV-1 psi (Ψ) packaging signal including a 5' terminal fragment of the gag sequence;
4. A env fragment that includes the Rev response element (RRE);
5. A 156 base pol fragment (FLAP) from coordinates 4327 to 4483 of HIV-1 SG3 molecular clone (see Ghosh, *et. al.* Virology, 194(2), 858-864, 1993) containing a central polypurine tract (cPPT) and central termination site (CTS), which is required for efficient translocation of the pre-integration complex across the nuclear envelope;
6. The polypurine track (ppt), which facilitates initiation of plus-strand DNA synthesis; and
7. A 3' LTR that lacks the enhancer elements located in the U3 region (ΔU3) needed for native transcriptional activity from the viral LTR. The deletion within the 3'-LTR results in a vector that is self-inactivating (SIN).

Trans-Lentiviral Packaging System:

The Trans-Lentiviral Packaging System offers a superior safety profile compared to other commercially available lentiviral vector systems. The packaging components are separated onto five plasmids (Figure 2). Additionally, expression of gag-pro and tat-rev are under the control of the conditional tetracycline-responsive promoter element (TRE), limiting expression of these viral components strictly to the packaging cell line. A detailed description of the Trans-Lentiviral Packaging System can be found in Wu, et. al. *Mol. Ther.* 2(1) 47-55, 2000.

The five plasmid components for the Trans-Lentiviral Packaging System are as follows:

1. pTLA1-PAK

The gag-pro packaging construct contains a DNA fragment from the HIV-1 molecular clone SG3 (coordinates 258 to 8384), which has been modified by a 39-base deletion of the packaging signal (Ψ) and a 1357-base deletion in the env gene (coordinates 5827 to 7184). The pol open reading frames (ORFs) for the RT and IN genes were deleted by replacing the first codon of each with stop codons (TAA). A frame-shift mutation was introduced into the Vpr-encoding sequence by blunt-end ligation at the Sall restriction site. Together these modifications delete the expression of RT, IN, as well as the accessory proteins, Vpr, Vif, Vpu, and Nef. Expression of Gag-Pro is controlled by a TRE promoter.

2. pTLA1-ENZ

The RT and IN proteins are packaged in the viral particle via an in-frame fusion with the virion-associated protein Vpr. Expression of the Vpr-RT-IN fusion polypeptide is under the control of the HIV-2 LTR, which is trans-activated by the Tat protein. Description of this construct can be found in Wu, et. al. *EMBO J.* 16, 5113-5122, 1997.

3. pTLA1-ENV

The VSV-G expression vector contains the VSV-G cDNA expressed from a human cytomegalovirus (CMV) immediate early promoter. In addition, an SV40 polyadenylation signal has been cloned downstream of the VSVg cDNA.

4. pTLA1-TOFF

The Tet-Off™ expression vector contains the tetracycline-controlled transactivator (tTA) under the control of the hCMV immediate early promoter. Tet-Off™ is required for transcriptional activation of Gag-Pro expression (pTLA1-PAK) and Tat/Rev expression (pTLA1-Tat/Rev).

5. pTLA1-Tat/Rev

The HIV-1 auxiliary proteins Tat and Rev are expressed from a bicistronic vector containing an Internal Ribosomal Entry Site (IRES). Its expression is under control of the TRE promoter. Tat expression is required for transactivation of the 5' LTRs found in SMARTvector Inducible Lentiviral shRNA and pTLA1-ENZ viral vectors. Rev is required for nuclear export and translation of mRNA transcripts encoding the gag-pro and vpr-RT-IN (pol) genes, as well as the full-length viral genome.

In addition, each of the packaging plasmids contains a pUC origin of replication for propagation in *E. coli*. and the beta lactamase (bla) gene for ampicillin resistance.

General Containment Considerations:

The major risks associated with the use of lentiviral vectors are (1) the potential for generating a replication competent lentivirus; and (2) the potential for oncogenesis due to insertional activation/inactivation of key regulatory genes; for example, activation of an oncogene or inactivation of a tumor suppressor.

To mitigate these risks, please follow the safety guidelines for use and production of vector-based lentivirus as set by your institution's biosafety committee.

- For glycerol stocks of *E. coli* containing lentiviral plasmids, BSL1 guidelines should be followed
- For handling and use of lentiviral products to produce lentiviral particles, BSL2 or BSL2+ guidelines should be followed
- For handling and use of lentiviral particle products, BSL2 or BSL2+ guidelines should be followed

For guidance on containment for lentiviral vectors, please refer to the Recombinant DNA Advisory Committee (RAC) guidelines for research with lentiviral vectors: oba.od.nih.gov/oba/rac/Guidance/LentiVirus_Containment/pdf/Lenti_Containment_Guidance.pdf

The Trans-Lentiviral Packaging System used to create SMARTvector Inducible Lentiviral shRNA lentiviral particles ensures that the enduser receives a safe product that can be effectively used in a BSL-2 environment to silence gene expression in a wide range of cell types. It is vital that the protocols supplied with the viral particle product for appropriate handling and storage are fully understood and followed precisely. We strongly advise that users of this product have extensive experience with cell culture techniques.

Any investigator who purchases SMARTvector Inducible lentiviral particle products is responsible for consulting with their institution's health and biosafety personnel for specific guidelines on the handling of lentiviral vector particles. Further, each investigator is fully responsible for obtaining the required permissions for the acceptance of lentiviral particles into their local geography and institution.

In the US, download the U.S. Department of Health and Human Services Centers for Disease Control and Prevention and National Institutes of Health, Biosafety in Microbiological and Biomedical Laboratories (BMBL), Fifth Edition, Feb 2007 here:

cdc.gov/biosafety/publications/index.htm

See also: NIH Guidelines For Research Involving Recombinant DNA Molecules (NIH Guidelines), September 2009, downloadable here:

oba.od.nih.gov/rdna/nih_guidelines_oba.html

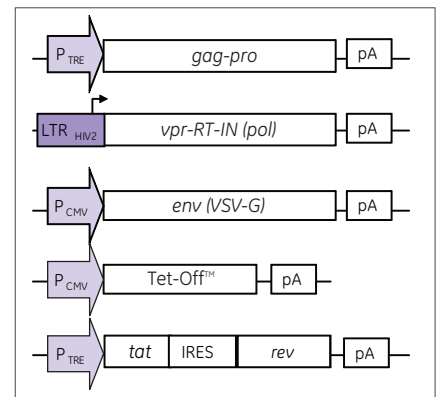

Figure 2. Trans-Lentiviral Packaging System

Tet-Off is a trademark of Tet Systems. GE, imagination at work and GE monogram are trademarks of General Electric Company. Dharmacon is a trademark GE Healthcare companies. All other trademarks are the property of General Electric Company or one of its subsidiaries. ©2017 General Electric Company—All rights reserved. First version published June 2017. GE Healthcare UK Limited, Amersham Place, Little Chalfont, Buckinghamshire, HP7 9NA, UK



Orders can be placed at:
gelifesciences.com/dharmacon

Customer Support: cs.dharmacon@ge.com
Technical Support: ts.dharmacon@ge.com
1.800.235.9880; 303.604.9499 if you have any questions.